



CAPPED OTTOMAN

PRODUCT SPECIFICATIONS





CAPPED OTTOMAN



The Capped Ottoman from the Winya collection is an exclusive piece of furniture designed to elevate any space. It features a stylish two-tone finish with nylon button glides and castors for easy mobility. The upholstery is thoughtfully crafted with Indigenous-inspired design elements. It is one of the best ottomans to suit your modern aesthetic and functional needs.

KEY FEATURES

- Full upholstered at COM
- Two-tone upholstery
- Nylon button glides

OPTIONS

- Indigenous designed upholstery
- Castors

LEAD TIME & WARRANTY

- 6-8 week lead time
- 5 year warranty

CERTIFICATIONS

- Made in Australia
- GECA Certified (foam)
- FSC Certified (timber internals)



CAPPED OTTOMAN

DIMENSIONS

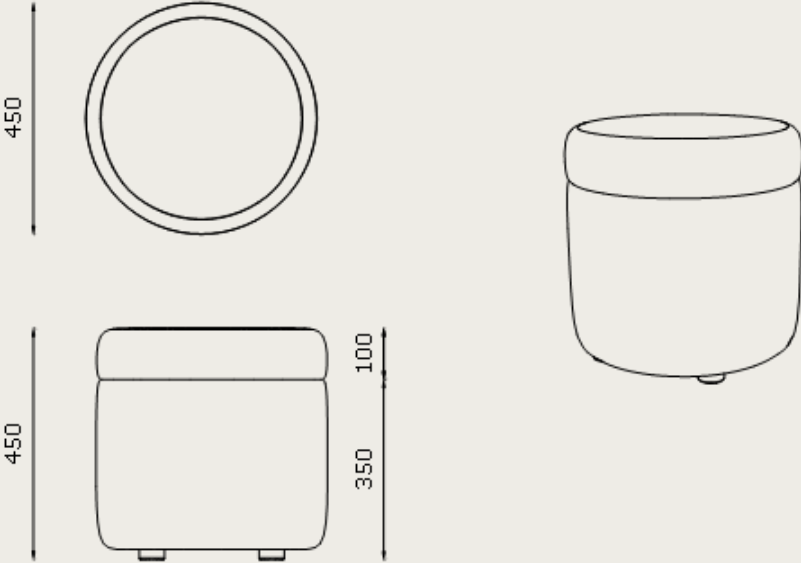





WINYA HOUSE FABRIC UPHOLSTERY

CAT. A WARWICK HAWTHORN

HD



Hawthorn
Natural



Hawthorn
Silver



Hawthorn
Pumice



Hawthorn
Taupe



Hawthorn
Blush



Hawthorn
Rosewood



Hawthorn
Mist



Hawthorn
Mink



Hawthorn
Forest



Hawthorn
Olive



Hawthorn
Manuka



Hawthorn
Earth



Hawthorn
Seafoam



Hawthorn
Sky

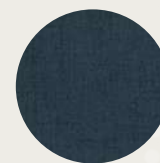

Hawthorn
Denim

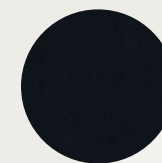

Hawthorn
Navy



Hawthorn
Onyx



Celebrating Culture through Furniture



WINYA INDIGENOUS FABRIC

Winya partners with Indigenous artists nationwide to create unique upholstery designs for furniture and acoustic products, bringing rich First Nations stories and culture into contemporary spaces.

Below is a preview of our Indigenous fabric collection. Refer to our [Indigenous Design Catalogue](#) on our website for the full range.

HAND STITCHED



Bianca Gardiner-Dodd
(Kamilaroi/Bundjalung)
BGD712



Murdie Nampijinpa Morris
(Warlpiri)
MNM652



Damien & Yilpi Marks
(W. Arrente/Warlpiri/APY)
"Dry Season #2"



Cedric Varcoe
(Ngarrindjeri)
"Ngurunderi"



Andrea Mimpitja Adamson
(APY Lands)
"Seven Sisters Creation Story"



Nora Nyutjanka Davidson
(Ngaanyatjarra)
"Digging for Honey Ants"

DIGITALLY PRINTED



Lucinda Johnson-Cornes
(Pitjantjatjara)
"Mapping Home"



Melissa Barton
(Dharug)
MB001

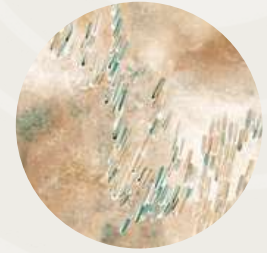

Lizzy Stageman
(Wiradjuri/Barkindji)
"Against The Elements"



Rosie Ngwarraye Ross
(Ampilatwatja)
"Sugarbag Dreaming Saltbush"



Mim Cole
(Larrakia)
"Family Love"



Jimmy Pike
(Walmajarri)
"Meandering Mirage"

Featured above:
Lucinda Johnson-Cornes
(Pitjantjatjara)
"Front Yard Gum"



Winya Indigenous Commercial Furniture
www.winya.com.au
info@winya.com.au
1300 184 799